



186HT/886HT Single Bellows Seals

- Proven performance in high temperature services
- Versatile slotted gland design
- Cartridge seal designed to fit standard pump bores
- Available for ANSI/ISO and API pump models
- Easily replaces OEM component seals



*Reliable high temperature
bellows seals for the most
demanding services*

186HT/886HT Single Bellows Seals

Construction Details

- 1 High temperature grafoil secondary seals
- 2 Advanced bellows design for maximum cycle life
- 3 Heat-treated AM350 bellows core
- 4 Rotating bellows eliminates clogging
- 5 Low expansion alloy
- 6 Blister-resistant carbon
- 7 Anti-coke throttle bushing
- 8 Full featured gland with flush, quench/vent and drain

Popular Configurations

Chesterton's superior bellows technology comes packaged in an array of seal configurations.

- 186HT standard ANSI/ISO pump design
- 186HTX thin cross-section for small pump frames
- 186HTA designed for API pumps
- 886HT replaces OEM seals

Materials

Universal, advanced seal materials for use in a broad range of high temperature sealing applications.

- Blister-resistant antimony carbon
- High heat transfer, chemically resistant silicon carbide
- Heat-treated AM350 bellows core
- Low expansion alloy face retainer
- Optional heat treated Inconel 718 bellows for corrosive services
- High temperature grafoil secondary seals

Advanced Bellows Design

To meet the challenges in the sealing industry, Chesterton now offers the proven, nesting ripple bellows design. With the nesting ripple design, all bellows plates are identical and contoured to permit nesting when compressed. Nesting distributes pressure uniformly across the span of the bellows plate. The end result is less stress and minimized weld fatigue.

- Higher pressure capability
- Maximum axial motion
- Compact bellows design
- Low stresses at the ID weld joints

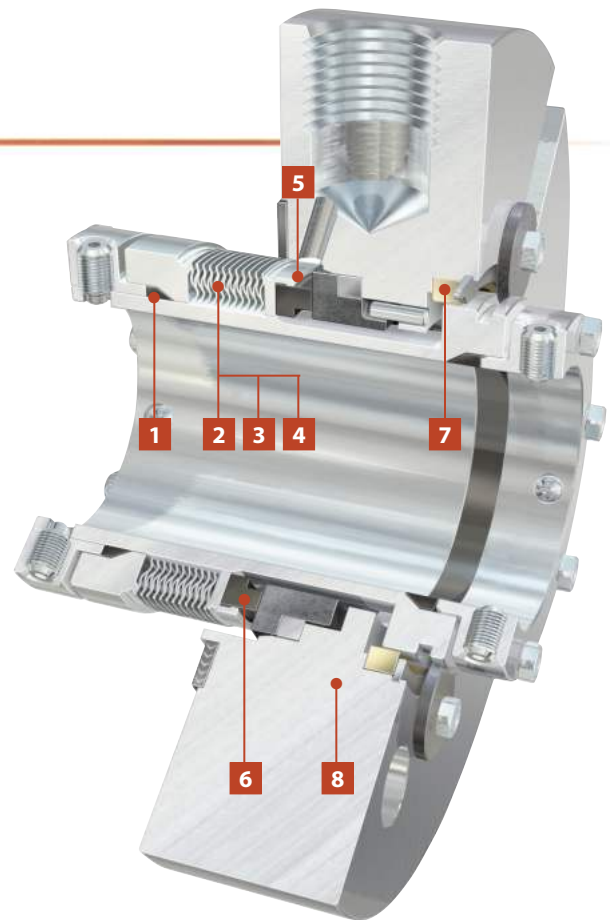

Greater Seal Reliability

To achieve maximum bellows plate thickness while not compromising the bellows spring rate, Chesterton uses a twelve convolution bellows core, which means controlled spring rate, lower heat generation and greater seal reliability throughout the operating range. The industry standard is nine convolutions.

- Low spring rate
- Low heat generation
- Reduced coking at the seal faces
- Minimized face load variations
- Provides consistent fluid film
- Less sensitive to installation tolerances
- Forgiving to variations in equipment tolerances

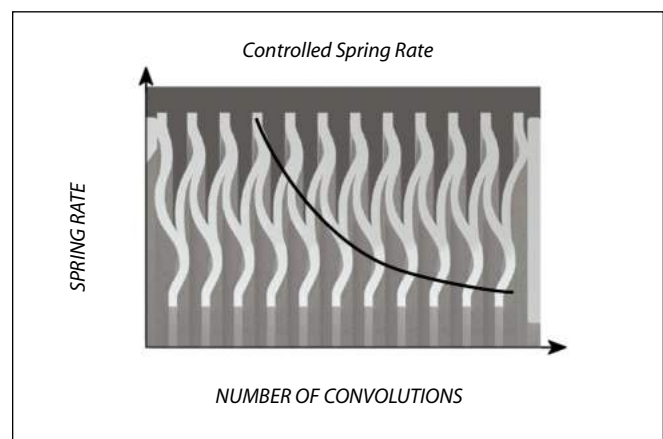

186HT STANDARD– Dimensional Data/Inch & Metric

SHAFT SIZE	GLAND OD	STUFFING BOX BORE	API BOX BORE	IB SEAL DIA	SB DEPTH	OB LENGTH	API OB LENGTH	BOLT CIRCLE BY BOLT SIZE			SLOT WIDTH	GLAND WIDTH	NPT
								A	B MAX	C MIN			
25mm	108	48	54	46	42	49	52	3/8" (10mm)	76	78	13	32	3/8
1.125	4.25	2.00	2.25	1.94	1.64	1.92	2.05	1/2" (12mm)	3.12	3.24	0.50	1.26	3/8
1.125-X	4.25	1.88†	2.13	0.81	1.58	1.92	2.05	5/8" (16mm)	2.87		0.44	1.26	3/8
30mm	108	51	57	49	42	49	52		79	82	13	32	3/8
1.250	4.50	2.25	2.38	2.17	1.68	1.92	2.05		3.19	3.31	0.50	1.26	3/8
32mm	114	57	60	55	43	49	52		81	99	13	32	3/8
1.375	4.75	2.38	2.63	2.30	1.68	1.99	2.11		3.49	3.62	0.56	1.32	3/8
1.375-X	4.25	2.13††	2.38	2.06	1.64	1.92	2.05		3.24		0.44	1.26	3/8
35mm	121	60	67	58	43	50	54		89	92	14	34	3/8
38mm	133	64	70	61	43	50	54		92	95	14	34	1/2
1.500	5.25	2.50	2.75	2.42	1.68	1.99	2.11		3.62	3.74	0.56	1.32	1/2
40mm	140	67	73	65	43	50	54		95	98	14	34	1/2
1.625	5.50	2.63	2.88	2.55	1.68	1.99	2.11		3.74	3.87	0.56	1.32	1/2
42mm	140	67	73	65	43	50	54		95	98	14	34	1/2
1.750	5.75	2.75	3.00	2.67	1.68	1.99	2.11		3.87	3.99	0.56	1.32	1/2
45mm	146	70	76	68	43	50	54		98	101	14	34	1/2
1.875	6.00	2.88	3.25	2.80	1.80	2.05	2.17		4.12	4.24	0.56	1.38	1/2
50mm	159	76	80	74	46	52	55		108	111	18	35	1/2
2.000	6.25	3.00	3.38	2.92	1.80	2.05	2.17		4.24	4.37	0.69	1.38	1/2
2.125	6.25	3.13	3.50	3.05	1.80	2.05	2.17		4.37	4.49	0.69	1.38	1/2
55mm	159	79	89	77	46	52	55		111	114	18	35	1/2
2.250	6.50	3.25	3.63	3.19	1.80	2.05	2.17		4.49	4.62	0.69	1.38	1/2
60mm	165	86	92	84	46	54	57		114	117	18	37	1/2
2.375	6.50	3.38	3.63	3.31	1.80	2.11	2.24		4.49	4.62	0.69	1.45	1/2
2.500	6.50	3.50	3.75	3.44	1.80	2.11	2.24		4.62	4.74	0.69	1.45	1/2
65mm	165	89	95	87	46	54	57		117	120	18	37	1/2
2.625	6.75	3.75	4.00	3.63	1.83	2.11	2.24		4.87	4.99	0.69	1.45	1/2

186HTOS OVERSIZE– Dimensional Data/Inch

SHAFT SIZE	GLAND OD	STUFFING BOX BORE	API BOX BORE	IB SEAL DIA	SB DEPTH	OB LENGTH	API OB LENGTH	BOLT CIRCLE BY BOLT SIZE			SLOT WIDTH	GLAND WIDTH	NPT
								A	B MAX	C MIN			
1.375	5.25	2.88	3.00	2.30	1.68	1.99	2.11	3/8"	3.92		0.44	1.32	1/2
1.750	6.50	3.50	3.63	2.67	1.68	1.99	2.11	1/2"	4.92	5.04	0.69	1.32	1/2
1.875	6.00	3.63	3.75	2.80	1.38	2.47	2.60	5/8"	4.79	4.92	0.56	1.81	1/2
2.125	7.25	3.88	4.00	3.05	1.80	2.05	2.17		4.92	5.04	0.69	1.38	1/2
2.500	8.00	4.75	4.88	3.44	1.80	2.11	2.24		6.42	6.54	0.69	1.45	1/2
2.625	7.00	4.63	4.75	3.63	1.83	2.11	2.24		5.79	5.92	0.56	1.45	1/2

* Minimum Bore Diameter Ca for ID Pilot

** OB Length Fa with Pilot design and metallic face gasket

† Note: Bore to be opened from 1.750 => 1.875 for Durco MK II & III Gr I Pumps

†† Note: Bore to be opened from 2.000 => 2.125 for Goulds 3196 ST Pumps

186HT/886HT Specifications

STANDARD MATERIALS

Rotary Faces:

- Blister-resistant Carbon
- Tungsten Carbide

Stationary Faces:

- Sintered Silicon Carbide

Major Metal Parts:

- 316SS

Bellows:

- AM350 heat-treated
- 718 Inconel heat-treated (corrosive services)

End Fittings:

- Low expansion alloy 42

Secondary Seals:

- Grafoil packing

OPERATING LIMITS

Speed Limits:

- To 4000 fpm (20 mps)

Temperature Limits:

- 100°F to 800°F (-73°C to 427°C)

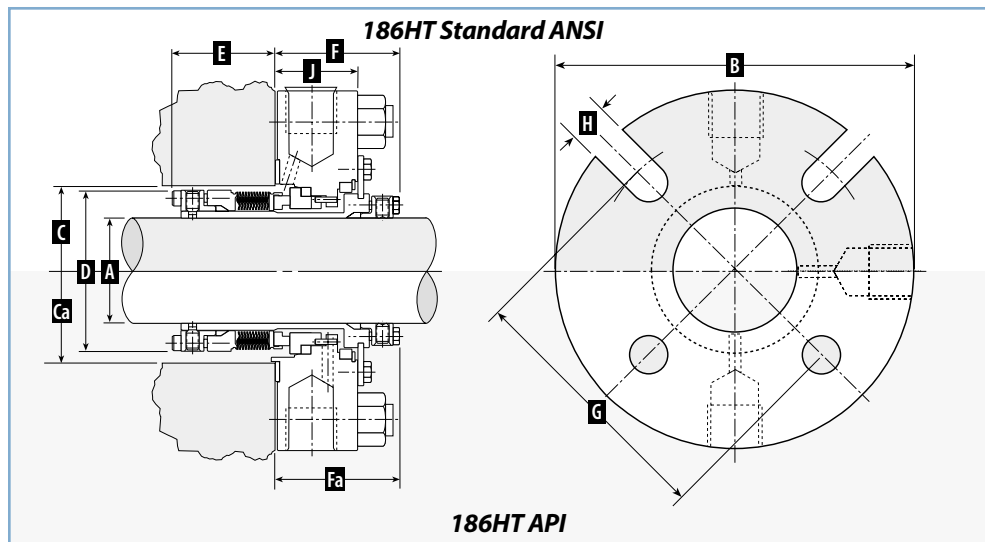

886HT Single Component Bellows Seals

886HT ROTARY ASSEMBLY – Dimensional Data/Inch

SHAFT SIZE	OUTSIDE DIA	OPERATING LENGTH	SCREW HEAD PROTRUSION
A	B	C	D
1.000	1.562	1.687	.125
1.125	1.687	1.562	.125
1.250	1.812	1.562	.125
1.375	1.937	1.750	.125
1.500	2.170	1.750	.164
1.625	2.295	1.750	.164
1.750	2.420	1.750	.164
1.875	2.545	1.750	.164
2.000	2.670	1.750	.164
2.125	2.795	1.750	.164
2.250	2.920	1.875	.164
2.375	3.045	1.875	.164
2.500	3.187	1.875	.164
2.625	3.312	1.875	.164

886HT ROTARY ASSEMBLY – Dimensional Data/Metric

SHAFT SIZE	OUTSIDE DIA	OPERATING LENGTH	SCREW HEAD PROTRUSION
A	B	C	D
25mm	39.7	42.8	3.2
28mm	42.8	39.7	3.2
30mm	46.0	42.8	3.2
32mm	46.0	42.8	3.2
35mm	49.2	44.5	3.2
38mm	55.1	44.5	4.2
40mm	58.3	44.5	4.2
42mm	61.5	44.5	4.2
45mm	62.3	44.5	4.2
48mm	64.6	44.5	4.2
50mm	67.8	44.5	4.2
55mm	74.2	47.6	4.2
60mm	77.3	47.6	4.2
65mm	84.1	47.6	4.2

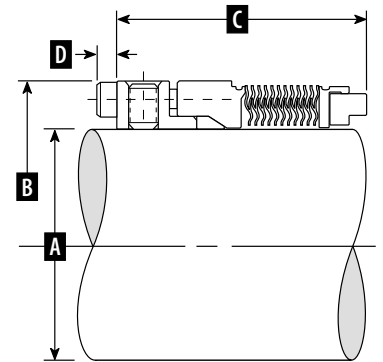

886HT STATIONARY ASSEMBLY – Dimensional Data/Inch & Metric

SHAFT SIZE	STAT. BORE DIA	STAT. LENGTH	CAVITY STEP DIA	CAVITY DEPTH	BORE DEPTH	CAVITY STEP DEPTH	NOSE LENGTH	PIN EXTRUSION
A	B	C	D	E	F	G	H	J
25mm	41.2	11.1	35.1	14.0	9.9	6.1	6.6	3.1
1.000	1.625	.437	1.384	.551	.390	.240	.261	.125
28mm	44.4	11.1	38.3	14.0	9.9	6.1	6.6	3.1
1.125	1.750	.437	1.509	.551	.390	.240	.261	.125
30/32mm	47.6	11.1	41.5	14.0	9.9	6.1	6.6	3.1
1.250	1.875	.437	1.634	.551	.390	.240	.261	.125
35mm	50.8	11.1	44.6	14.0	9.9	6.1	6.6	3.1
1.375	2.000	.437	1.759	.551	.390	.240	.261	.125
38mm	53.9	11.1	47.8	14.0	9.9	6.1	6.6	3.1
1.500	2.125	.437	1.884	.551	.390	.240	.261	.125
40mm	60.3	12.7	54.2	15.0	10.9	6.3	7.9	3.1
1.625	2.375	.500	2.134	.592	.431	.251	.314	.125
42mm	63.5	12.7	57.3	15.0	10.9	6.3	7.9	3.1
1.750	2.500	.500	2.259	.592	.431	.251	.314	.125
45mm	66.6	12.7	60.5	15.0	10.9	6.3	7.9	3.1
1.875	2.625	.500	2.384	.592	.431	.251	.314	.125
48mm	69.8	12.7	63.7	15.0	10.9	6.3	7.9	3.1
2.000	2.750	.500	2.509	.592	.431	.251	.314	.125
50mm	76.2	14.2	70.0	16.2	12.1	7.6	8.7	3.9
2.125	3.000	.562	2.759	.641	.480	.300	.346	.156
55mm	79.3	14.2	73.2	16.2	12.1	7.6	8.7	3.9
2.250	3.125	.562	2.884	.641	.480	.300	.346	.156
60mm	82.5	14.2	76.4	16.2	12.1	7.6	8.7	3.9
2.375	3.250	.562	3.009	.641	.480	.300	.346	.156
2.500	3.375	.562	3.134	.641	.480	.300	.346	.156
65mm	85.7	15.8	79.6	17.3	13.2	8.6	9.6	4.3
2.625	3.375	.625	3.134	.682	.521	.341	.379	.170

