

# 250™ Cartridge Dual Seal

## Installation, Operation and Maintenance Instructions



### TABLE OF CONTENTS

1.0	Cautions.....	2
2.0	Transport and Storage.....	2
3.0	Description.....	2 - 5
3.1	Parts Identification.....	2
3.2	Operating Parameters.....	3
3.3	Intended Use.....	3
3.4	Dimensional Data.....	3 - 5
4.0	Preparation for Installation.....	6 - 7
4.1	Equipment.....	6
5.0	Seal Installation.....	7
6.0	Commissioning/Equipment Start-up.....	8
7.0	Decommissioning/Equipment Shut-down.....	8
8.0	Spare Parts.....	8
9.0	Seal Maintenance and Repair.....	8
9.1	Seal Maintenance.....	8
9.2	Returning Seals for Repair.....	8

Product may be provided with cast gland.

## 1.0 CAUTIONS

These instructions are general in nature. It is assumed that the installer is familiar with seals and certainly with the requirements of their plant for the successful use of mechanical seals. If in doubt, get assistance from someone in the plant who is familiar with seals or delay the installation until a seal representative is available. All necessary auxiliary arrangements for successful operation (heating, cooling, flushing) as well as safety devices must be employed. These decisions are to be made by the user. The decision to use this seal or any other Chesterton seal in a particular service is the customer's responsibility.

Do not touch the mechanical seal for any reason while it is operating. Lockout or uncouple the driver prior to personal contact with the seal. Do not touch the mechanical seal while it is in contact with hot or cold fluids. Ensure that all the mechanical seal materials are compatible with the process fluid. This will prevent possible personal injury.

## 2.0 TRANSPORT AND STORAGE

Transport and store seals in their original packaging. Mechanical seals contain components that may be subject to alteration and ageing. It is therefore important to observe the following conditions for storage:

- Dust free environment
- Moderately ventilated at room temperature
- Avoid exposure to direct sunlight and heat
- For elastomers, storage conditions according to ISO 2230 should be observed.

## 3.0 DESCRIPTION

### 3.1 Parts Identification – Figure 1

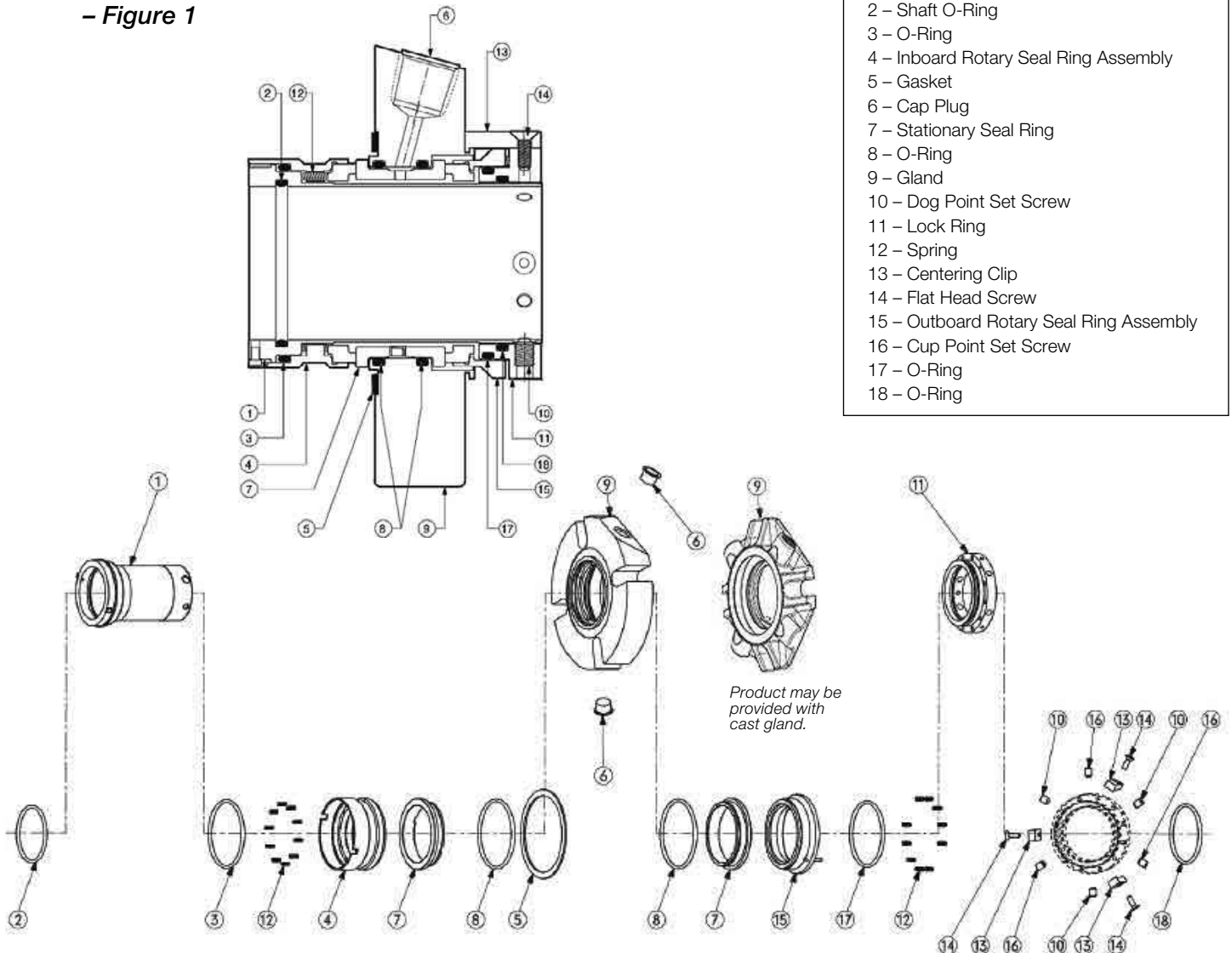

### 3.0 DESCRIPTION cont.

#### 3.2 Operating Parameters\*

**Pressure:**

Inboard – Up to 21 bar g (300 psig)  
 Outboard – Up to 10 bar g (150 psig)

*Seal pressure capabilities are dependent on the fluid sealed, temperature, speed and seal face combinations.*

**Speed Limits:**

Up to 4000 FPM

**Temperature Limits:**

*Elastomers*

To 150°C (300°F) EPDM  
 To 205°C (400°F) FEPM, FKM  
 To 260°C (500°F) Perfluoroelastomer

**Standard Materials:**

All Metal Parts: 316 SS / EN 1.4401  
 Springs: Alloy C276 / EN 2.4819  
 Rotary Face: Carbon; Silicon Carbide  
 Stationary Face: Silicon Carbide  
 Elastomers: FKM; EPDM; FEPM; Perfluoroelastomer

*\* Consult Chesterton Mechanical Seal Application Engineering for higher operating conditions.*

#### 3.3 Intended Use

The mechanical seal is specifically designed for the intended application and is to be operated within the operating parameters as specified. For use beyond the intended application and/or outside the operating parameters, consult Chesterton to confirm the suitability of the mechanical seal prior to putting the mechanical seal in operation.

#### 3.4 Dimensional Data – Figure 2

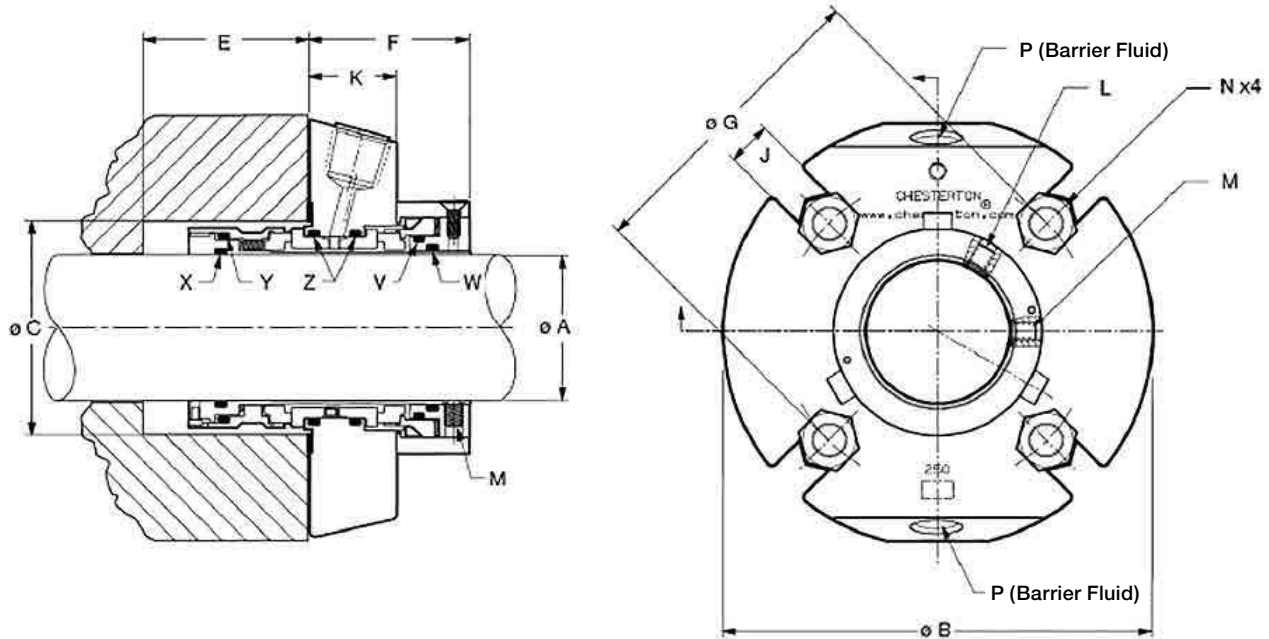

A (SHAFT SIZE)	P (NPT SIZE)
25 mm – 38 mm (1" – 1.500")	1/4 – 18 NPT
40 mm – 68 mm (1.625" – 2.625")	3/8 – 18 NPT
70 mm – 120 mm (2.750" – 4.750")	1/2 – 14 NPT



*Product may be provided with cast gland; fits in same envelope as machined gland.*

### 3.0 DESCRIPTION cont.

**Dimensional Data (inch) – Table 2**

A	B	C		E MIN	F	G MIN			J	K	V	W	X	Y	Z
		MIN	MAX			3/8	1/2	5/8							
0.938	4.11	1.63	2.01	1.44	2.06	2.88	-	-	0.44	1.12	123	122	119	027	126
1.000	4.11	1.63	2.01	1.44	2.06	2.88	-	-	0.44	1.12	123	122	120	027	126
1.063	4.11	1.75	2.04	1.44	2.06	2.88	-	-	0.44	1.12	125	123	121	029	128
1.125	4.11	1.75	2.04	1.44	2.06	2.88	-	-	0.44	1.12	125	124	122	029	128
1.125 OS*	4.49	2.50	2.75	1.44	2.06	3.58	-	-	0.44	1.12	125	124	122	029	128
1.188	4.11	1.88	2.27	1.44	2.06	3.12	-	-	0.44	1.12	127	126	123	029	130
1.250	4.11	1.88	2.27	1.44	2.06	3.12	-	-	0.44	1.12	127	126	124	029	130
1.313	4.36	2.00	2.33	1.44	2.06	3.13	3.25	-	0.57	1.12	129	128	125	030	132
1.375	4.36	2.00	2.33	1.44	2.06	3.13	3.25	-	0.57	1.12	129	128	126	030	132
1.375 OS*	5.39	2.68	3.00	1.44	2.06	3.71	-	-	0.44	1.12	129	128	126	030	132
1.438	4.49	2.25	2.62	1.53	2.06	3.36	3.49	-	0.57	1.12	133	130	128	134	135
1.500	4.49	2.25	2.62	1.53	2.06	3.36	3.49	-	0.57	1.12	133	130	128	134	135
1.563	4.99	2.38	2.68	1.53	2.06	3.54	3.66	-	0.57	1.12	134	131	129	135	137
1.625	4.99	2.38	2.68	1.53	2.06	3.54	3.66	-	0.57	1.12	135	132	130	136	137
1.688	5.49	2.50	2.81	1.53	2.06	3.63	3.76	-	0.57	1.12	136	133	131	137	139
1.750	5.49	2.50	2.81	1.53	2.06	3.63	3.76	-	0.57	1.12	137	134	132	138	139
1.750 OS*	6.64	3.37	3.75	1.53	2.06	4.63	4.75	-	0.57	1.12	137	134	132	138	139
1.813	5.49	2.63	2.94	1.53	2.06	3.76	3.89	-	0.57	1.12	138	136	134	140	141
1.875	5.49	2.63	2.94	1.53	2.06	3.76	3.89	-	0.57	1.12	138	136	134	140	141
1.875 OS*	5.99	3.42	3.81	1.53	2.06	-	4.80	-	0.57	1.12	138	136	134	140	141
1.938	5.49	2.75	3.19	1.53	2.06	4.01	4.14	-	0.57	1.12	140	137	136	141	143
2.000	5.49	2.75	3.19	1.53	2.06	4.01	4.14	-	0.57	1.12	141	138	136	142	143
2.063	5.99	2.88	3.44	1.53	2.06	4.26	4.39	4.50	0.69	1.12	143	140	138	144	145
2.125	5.99	2.88	3.44	1.53	2.06	4.26	4.39	4.50	0.69	1.12	143	140	138	144	145
2.125 OS*	6.99	3.75	4.25	1.53	2.06	-	-	5.37	0.69	1.12	143	140	138	144	145
2.188	5.99	3.00	3.56	1.53	2.06	4.38	4.51	4.62	0.69	1.12	145	142	140	146	147
2.250	5.99	3.00	3.56	1.53	2.06	4.38	4.51	4.62	0.69	1.12	145	142	140	146	147
2.313	5.99	3.13	3.59	1.53	2.06	4.44	4.57	4.68	0.69	1.12	147	144	142	148	149
2.375	5.99	3.13	3.59	1.53	2.06	4.44	4.57	4.68	0.69	1.12	147	144	142	148	149
2.375 OS*	8.40	4.13	4.50	1.53	2.06	-	-	5.62	0.69	1.12	147	144	142	148	149
2.438	6.49	3.25	3.81	1.53	2.06	4.63	4.76	4.87	0.69	1.12	149	146	144	150	151
2.500	6.49	3.25	3.81	1.53	2.06	4.63	4.76	4.87	0.69	1.12	149	146	144	150	151
2.500 OS*	7.77	4.37	4.75	1.53	2.06	-	-	6.37	0.69	1.12	149	146	144	150	151
2.563	6.45	3.38	3.94	1.53	2.06	4.91	5.04	5.15	0.69	1.12	150	148	146	151	151
2.625	6.45	3.38	3.94	1.53	2.06	4.91	5.04	5.15	0.69	1.12	150	148	146	151	151
2.625 OS*	6.98	4.38	4.78	1.53	2.06	-	-	5.90	0.69	1.12	150	148	146	151	152

\*OS = oversize

						1/2	5/8	3/4							
2.688	7.70	3.75	4.38	2.29	2.50	5.42	5.55	-	0.69	1.41	235	234	232	236	238
2.750	7.70	3.75	4.38	2.29	2.50	5.42	5.55	-	0.69	1.41	235	234	232	236	238
2.813	7.83	3.88	4.50	2.29	2.50	5.50	5.62	-	0.69	1.41	236	235	233	237	239
2.875	7.83	3.88	4.50	2.29	2.50	5.50	5.62	-	0.69	1.41	236	235	233	237	239
2.938	7.94	4.00	4.69	2.29	2.50	5.65	5.77	-	0.69	1.41	237	236	234	238	240
3.000	7.94	4.00	4.69	2.29	2.50	5.65	5.77	-	0.69	1.41	237	236	234	238	240
3.000 OS*	8.64	4.93	5.39	2.29	2.50	6.31	6.44	6.56	0.94	1.41	237	236	234	238	240
3.063	7.99	4.13	4.81	2.29	2.50	5.80	5.92	-	0.69	1.41	238	237	235	239	241
3.125	7.99	4.13	4.81	2.29	2.50	5.80	5.92	-	0.69	1.41	238	237	235	239	241
3.188	8.19	4.25	4.94	2.29	2.50	5.93	6.05	-	0.69	1.41	239	238	236	240	242
3.250	8.19	4.25	4.94	2.29	2.50	5.93	6.05	-	0.69	1.41	239	238	236	240	242
3.313	8.30	4.38	5.06	2.29	2.50	6.02	6.14	6.27	0.81	1.41	240	239	237	241	243
3.375	8.30	4.38	5.06	2.29	2.50	6.02	6.14	6.27	0.81	1.41	240	239	237	241	243
3.438	8.44	4.50	5.19	2.29	2.50	6.18	6.31	6.43	0.81	1.41	241	240	238	242	244
3.500	8.44	4.50	5.19	2.29	2.50	6.18	6.31	6.43	0.81	1.41	241	240	238	242	244
3.563	8.49	4.63	5.31	2.29	2.50	6.31	6.44	6.56	0.81	1.41	242	241	239	243	245
3.625	8.49	4.63	5.31	2.29	2.50	6.31	6.44	6.56	0.81	1.41	242	241	239	243	245
3.688	8.71	4.75	5.39	2.29	2.50	6.38	6.51	6.63	0.81	1.41	243	242	240	244	246
3.750	8.71	4.75	5.39	2.29	2.50	6.38	6.51	6.63	0.81	1.41	243	242	240	244	246
3.750 OS*	9.76	5.08	6.40	2.29	2.50	7.32	7.45	-	0.69	1.41	243	242	240	244	246
3.813	8.84	4.88	5.51	2.29	2.50	6.52	6.64	6.77	0.81	1.41	244	243	241	245	247
3.875	8.84	4.88	5.51	2.29	2.50	6.52	6.64	6.77	0.81	1.41	244	243	241	245	247
3.938	8.96	5.00	5.69	2.29	2.50	6.66	6.78	6.91	0.81	1.41	245	244	242	246	248
4.000	8.96	5.00	5.69	2.29	2.50	6.66	6.78	6.91	0.81	1.41	245	244	242	246	248
4.063	8.99	5.13	5.81	2.29	2.50	6.78	6.91	7.03	0.81	1.41	246	245	243	247	249
4.125	8.99	5.13	5.81	2.29	2.50	6.78	6.91	7.03	0.81	1.41	246	245	243	247	249
4.188	8.99	5.25	5.94	2.29	2.50	6.91	7.04	7.16	0.81	1.41	247	246	244	248	250
4.250	8.99	5.25	5.94	2.29	2.50	6.91	7.04	7.16	0.81	1.41	247	246	244	248	250
4.313	9.33	5.38	6.06	2.29	2.50	7.03	7.15	7.28	0.81	1.41	248	247	245	249	251
4.375	9.33	5.38	6.06	2.29	2.50	7.03	7.15	7.28	0.81	1.41	248	247	245	249	251
4.438	9.49	5.50	6.19	2.29	2.50	7.18	7.30	7.43	0.81	1.41	249	248	246	250	252
4.500	9.49	5.50	6.19	2.29	2.50	7.18	7.30	7.43	0.81	1.41	249	248	246	250	252
4.563	9.49	5.63	6.31	2.29	2.50	7.28	7.40	7.53	0.81	1.41	250	249	247	251	253
4.625	9.49	5.63	6.31	2.29	2.50	7.28	7.40	7.53	0.81	1.41	250	249	247	251	253
4.688	10.49	5.75	6.47	2.29	2.50	7.40	7.53	7.65	0.81	1.41	251	250	248	252	254
4.750	10.49	5.75	6.47	2.29	2.50	7.40	7.53	7.65	0.81	1.41	251	250	248	252	254

### 3.0 DESCRIPTION cont.

*Dimensional Data (metric) – Table 2*

A	B	C		E MIN	F	G MIN			J	K	V	W	X	Y	Z
		MIN	MAX			10 mm	12 mm	16 mm							
25	104	41	51	36.6	52.3	73	-	-	11.2	28	123	122	120	027	126
28	104	44	52	36.6	52.3	73	-	-	11.2	28	125	123	122	028	128
30	104	46	57	36.6	52.3	78	-	-	11.2	28	126	125	123	029	129
32	104	48	58	36.6	52.3	80	-	-	11.2	28	127	126	124	029	130
33	113	49	59	36.6	52.3	81	83	-	14.5	28	128	127	125	030	131
35	111	51	59	36.6	52.3	80	82	-	14.5	28	129	128	126	030	132
38	114	57	67	38.8	52.3	85.9	87.9	-	14.5	29	133	130	128	134	135
40	126	59	68	38.8	52.3	90.3	92.3	-	13.6	29	134	131	129	135	137
43	126	62	69	38.8	52.3	91.3	93.3	-	13.6	29	136	133	131	137	139
45	139	64	73	38.8	52.3	95.3	97.3	-	13.6	29	137	134	133	138	140
48	139	67	73	38.8	52.3	95.3	97.3	-	13.6	29	139	136	134	140	142
50	139	69	78	38.8	52.3	100.3	102.3	-	13.6	29	140	137	136	142	143
53	152	73	87	38.8	52.3	109	111	115	17.5	29	143	140	138	144	145
55	152	74	83	38.8	52.3	105.3	107.3	111.3	17.5	29	143	141	139	145	146
58	152	80	91	38.8	52.3	114	116	120	17.5	29	147	144	141	148	149
60	152	80	91	38.8	52.3	114	116	120	17.5	29	147	144	142	148	149
63	165	83	97	38.8	52.3	119	121	125	17.5	29	149	146	144	150	151
65	164	86	100	38.8	52.3	125.3	127.3	131.3	17.5	29	150	148	145	151	151
68	165	86	100	38.8	52.3	125.3	127.3	131.3	17.5	29	151	149	147	151	152
70	196	96	111	58.2	63.5	132	134	138	17.5	35.8	235	234	232	236	238
75	202	102	119	58.2	63.5	140	142	146	17.5	35.8	237	236	234	238	240
80	203	106	122	58.2	63.5	143	145	149	17.5	35.8	238	237	236	239	241
85	211	111	128	58.2	63.5	152	156	155	20.6	35.8	240	239	237	241	243
90	214	116	132	58.2	63.5	156	160	151	20.6	35.8	241	240	239	242	244
95	221	121	137	58.2	63.5	161	165	169	20.6	35.8	243	242	240	244	246
100	228	127	145	58.2	63.5	168	172	176	20.6	35.8	245	244	242	246	248
105	228	131	148	58.2	63.5	172	176	180	20.6	35.8	246	245	243	247	249
110	237	137	154	58.2	63.5	177	181	185	20.6	35.8	248	247	245	249	251
115	241	143	160	58.2	63.5	182	186	190	20.6	35.8	250	249	247	251	253
120	266	146	164	58.2	63.5	187	191	195	20.6	35.8	251	250	248	252	254

## 4.0 PREPARATION FOR INSTALLATION

### 4.1 Equipment

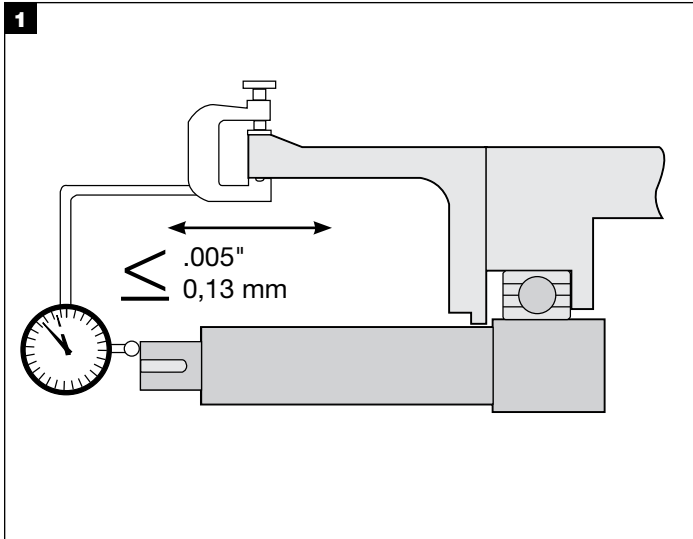

If practical, place the dial indicator tip on the end of the shaft sleeve or on a step in the shaft to measure end play. Alternately push and pull the shaft in the axial direction. If the bearings are in good condition, end play should not exceed 0,13 mm (.005").

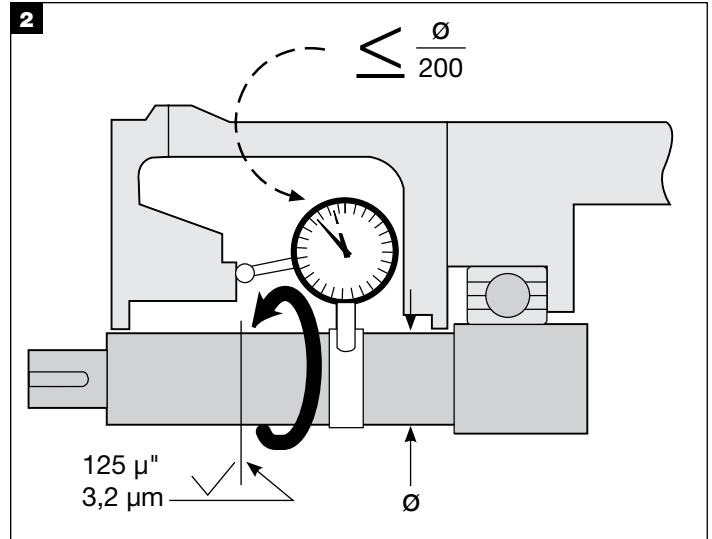

If possible, attach a base dial indicator to the shaft and rotate both the indicator and shaft slowly while reading the runout of the stuffing box face. Misalignment of the stuffing box face relative to the shaft should not exceed 0,005 mm TIR per mm (.005 in per inch) of shaft diameter.

The stuffing box face must be flat and smooth enough to seal the gland. Surface roughness should be 3,2 microns (125 microinch) Ra maximum for gaskets and 0,8 micron (32 microinch) Ra for O-rings. Steps between halves of split case pumps should be machined flat. Make sure the stuffing box is clean and clear along its entire length.

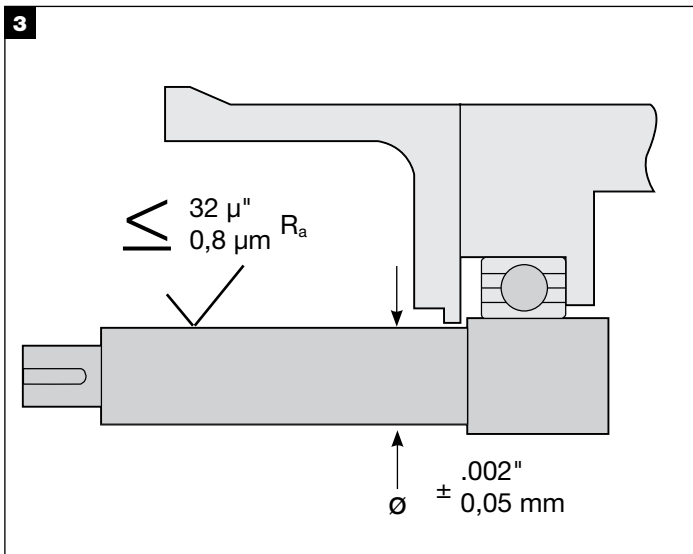

Remove all sharp corners, burrs, and scratches on the shaft, especially in areas where the O-ring will slide, and polish if necessary to achieve a 0,8 micron (32 microinch) Ra finish. Make sure the shaft or sleeve diameter is within 0,05 mm (.002") of nominal.

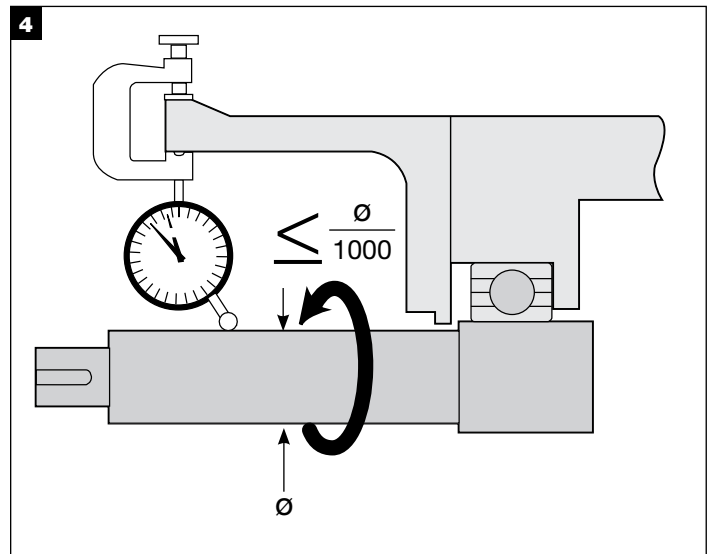

4. Use a dial indicator to measure the shaft runout in the area where the seal will be installed. Runout should not exceed 0,005 mm TIR per mm (.005 in per inch) of shaft diameter.



## 5.0 SEAL INSTALLATION

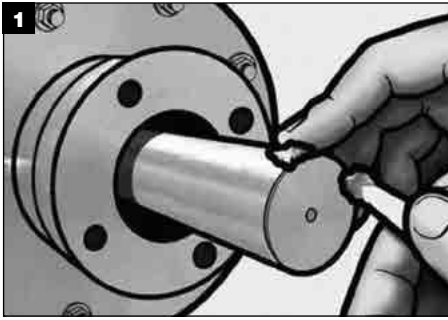

Apply a thin film of grease to the shaft diameter.

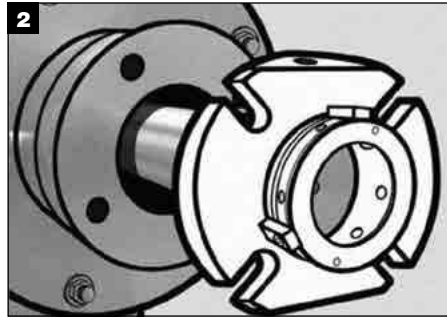

Slide the seal onto the shaft.

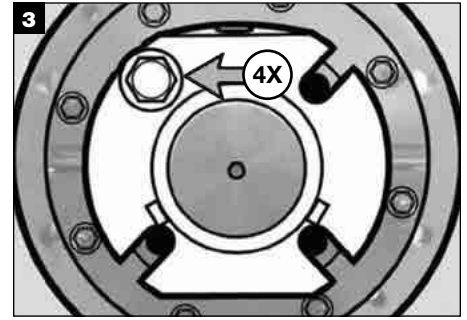

Align gland slots with bolt holes in stuffing box face and install bolts.

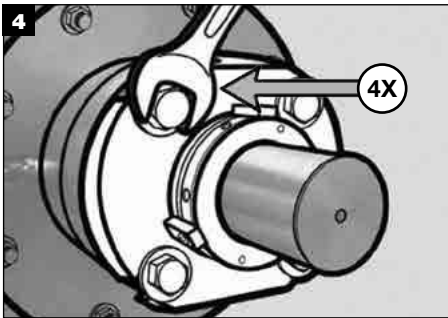

Tighten gland bolts evenly; torque to specified value in Table 3.

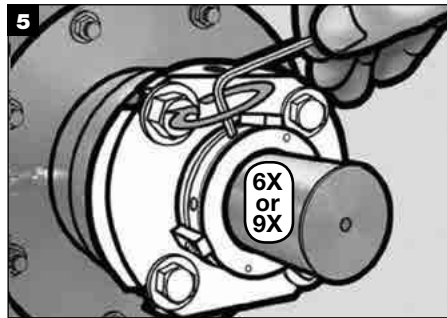

Tighten dog point set screws evenly; tighten cup point set screws evenly. Torque to specified value in Table 3.

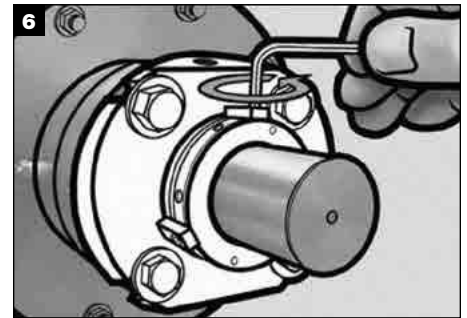

Loosen and remove flat head cap screws from centering clips.

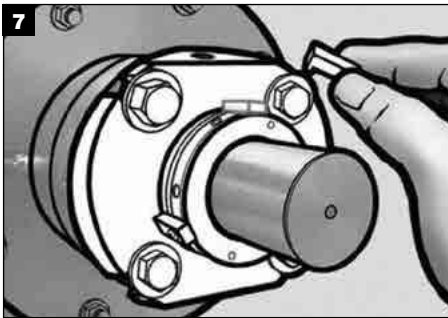

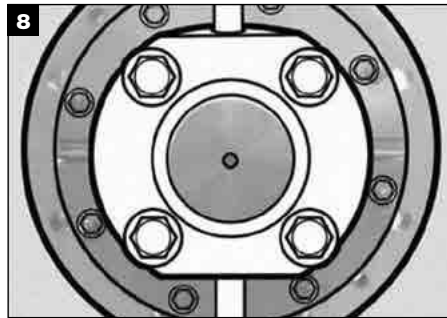

Completely remove 3 centering clips; retain screws and centering clips for future impeller adjustments or seal re-installation.



See Section 6.0 For Commissioning and Equipment Startup.

**Torque Values – Table 3**

A (SHAFT SIZE)	25 mm – 60 mm (1" – 2.500")	65 mm – 120 mm (2.625" – 4.750")
L 	5,7 – 6,8 Nm (50 – 60 in-lbf)	7,3 – 8,3 Nm (65 – 75 in-lbf)
M 	5,7 – 6,8 Nm (50 – 60 in-lbf)	7,3 – 8,3 Nm (65 – 75 in-lbf)
N 	27 – 40 Nm (20 – 30 ft-lbf)	27 – 40 Nm (20 – 30 ft-lbf)

## 6.0 COMMISSIONING / EQUIPMENT START UP

---

1. Rotate the shaft by hand, if possible, to ensure no metal-to-metal contact within the seal.
2. Attach appropriate plumbing/environmental controls to the seal. Take all necessary precautions and follow normal safety procedures before starting the equipment.

*Please contact Chesterton Mechanical Seal Application Engineering for assistance regarding cartridge dual seals.*

## 7.0 DECOMMISSIONING / EQUIPMENT SHUT DOWN

---

Ensure that the equipment is electrically isolated. If the equipment has been used on toxic or hazardous fluids, ensure that the equipment is correctly decontaminated and made safe prior to commencing work. Ensure that the pump is isolated and check that the stuffing box is drained from any

fluid and pressure is fully released. Disassemble the seal and remove from equipment in the reverse order from installation instructions. In case of disposal, ensure the local regulations and requirements for disposal or recycling of the different components in the seal are adhered to.

## 8.0 SPARE PARTS

---

Use only Chesterton original spare parts. Use of non-original spare parts represents risk of failure, danger to persons/equipment and voids the product warranty.

Spare Parts can be purchased from Chesterton.

## 9.0 SEAL MAINTENANCE AND REPAIR

---

### 9.1 Seal Maintenance

A correctly installed and operated mechanical seal requires little maintenance. It is recommended to periodically check the seal for leakage. Wearing components of a mechanical seal such as seal faces, O-ring, etc., require replacement over time. While a seal is installed and operating, maintenance is not possible. Therefore it is recommended that a spare seal unit or a spare parts kit be held in stock to allow quick repair.

Note the condition of the parts, including elastomer surfaces and gland springs. Analyze the cause of failure and correct the problem, if possible, before reinstalling the seal.

Clean all elastomer and gasket surfaces with cleaning solvent.

### 9.2 Returning Seals For Repair And Hazard Communication Requirements

Any mechanical seal returned to Chesterton that has been in operation, must comply with our Hazard Communication requirements. Please go to our web page at [\*\*www.chesterton.com/Mechanical\\_Seal>Returns\*\*](http://www.chesterton.com/Mechanical_Seal>Returns) to obtain information required for returning seals for repair or seal analysis.



DISTRIBUTED BY:

*Chesterton ISO certificates available on [www.chesterton.com/corporate/iso](http://www.chesterton.com/corporate/iso)*

860 Salem Street  
Groveland, MA 01834 USA  
Telephone: 781-438-7000 Fax: 978-469-6528  
[www.chesterton.com](http://www.chesterton.com)

© 2015 A.W. Chesterton Company.  
® Registered trademark owned and licensed by  
A.W. Chesterton Company in USA and other countries.

FORM NO. 096157 REV 3

11/15